

www.chinaxots.com

GOTS

Xizixiao Elevator Co.,Ltd

Factory Address: Mumianzai, Shatou Village, Sanjiang Shitan Town,
Zengcheng District, Guangdong, Guangzhou

Sales Office: Building B1\B2, Jinyu Commercial Area, Lijing Dadao,
Licheng Town, Zengcheng District, Guangzhou

The central production base: Chihu Industrial Zone Station,
Jiujiang Xian, Jiujiang, Jiangxi

The western production base: No.188, Shuanghua Road,
China Southern Airlines Economic Development Zone, Shuangliu Xian, Cheng du

Tel : +86-13226684419

Fax: 020-32633078

E-mail: xizixiaodt@chinaxots.com

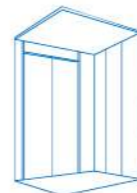

2016年版

• The Company Reserves The Right To Change The Product Design And The Explanation Right, Album Printing Is Different From The Real, All In Order To Prevail In Kind.

设计制作: 北京美广通 13822261314

GOTS

**OBSERVATION
ELEVATOR**
XIZIXIAO ELEVATOR CO., LTD



Bearing More Smoothly

Observation Elevator

Xizi Xiao series of observation elevators are a new type of elevators for transportation and tourism designed to meet people's pursuit of more joyful and refined lifestyle. The passengers can enjoy the beautiful scenery outside the building and the comfortable life experience brought by modern equipment in the processes of going upstairs and downstairs.

The wide and bright observation window of unique shape decorates the building, and expands the visual space of elevator.

The elevators adopt new fully computerized and modular variable velocity variable frequency (VVVF) control technology, integrate of the data network system and modular structure, and use the most effective self-test procedure to guarantee that the smooth running, accurate, flexible and efficient leveling. The elevators themselves become a beautiful scenery in the modern city, and have wider application in large buildings such as hotels, shopping malls and office buildings.

We offer elevators with observation windows of semicircle, square, and diamond design to meet various needs of users.



Intelligentize Control system

High Integrated Intelligent Control System



High Integrated Intelligent Control System

The fully computerized data network system of Xizi Xiao series of observation elevators demonstrates the people-oriented intelligence with improved functions and greater flexibilities; 32-bit dual CPUs and mutual monitoring of the main and auxiliary CPUs further improve the data processing speed; the highly intelligent microcomputer module incorporated within the system guarantees the most secure, accurate, and efficient management and control of the elevators.

The elevators also offer optional cutting-edge intelligent management module which enables community monitoring, IC card intelligent recognition, and authority management by perfectly combining elevator control technologies and communication technologies to greatly strengthen the security and intelligence of building management.



Permanent Magnet Synchronous Host

The thin permanent-magnet synchronous gearless traction motor of superior performance can reduce noise and vibration, and eliminate the possibility of failure during deceleration. Meanwhile, it also features the merits of small size, light weight and low power consumption.

The gearless traction motor significantly reduces the noise in the machine room to a maximum extent of 10dB comparing with the traditional worm drive.

In addition, permanent-magnet synchronous gearless traction motor needs no lubricant, which eliminates oil pollution and is more eco-friendly.

Frequency Conversion Machine

The intelligent and self-adaptive variable-frequency door motor system allows more flexible and reasonable adjustment of door opening and closing speed, so as to guarantee smooth and safe operation of the elevators.

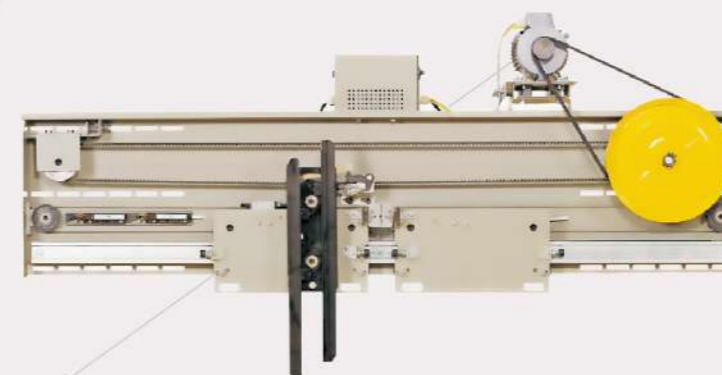

Semicircle Sightseeing Elevator



YMD-GG001 (standard)

Upper and lower shells: Ribbing steel panel with baked finish
 Window: 180° circular laminated glass
 Ceiling: Lamp holder of steel panel with baked finish, acrylic chandelier and downlight
 Car wall: stainless steel with capillary crack + laminated glass
 Armrest: φ 25 stainless steel single tube
 Floor: PVC floor



YMD-GG002 (optional)

Upper and lower shells: Stainless steel panel with capillary crack and steel panel with baked finish
 Two acrylic decorative lamp holders matching with milky white lampshades
 Window: Laminated glass
 Ceiling: Frame of steel panel with baked finish, lamps of subdued lighting design, acrylic light fixture in the middle
 Car wall: Streak-pattern stainless steel
 Floor: PVC floor



Square Observation Elevator



YMD-GG005 (standard)

Upper and lower shells: Spraying steel panel
 Window: Laminated glass
 Ceiling: HY-427
 Car wall: Laminated glass
 Armrest: Stainless steel single tube with capillary crack
 Floor: PVC floor



YMD-GG008 (optional)

Upper and lower shells: Steel panel with baked finish, and light fixture
 Window: Laminated glass
 Ceiling: Frame of steel panel with baked finish, acrylic top and light fixture on both sides
 Car wall: Stainless steel with capillary crack + laminated glass
 Armrest: φ 25 stainless steel double tubes
 Floor: PVC floor



Diamond Observation Elevator



YMD-GG003 (optional)

Upper and lower shells: Steel panel with baked finish, and light fixture in the lower shell
 Window: Flat laminated glass
 Ceiling: Frame of steel panel with baked finish, and acrylic light fixture
 Car wall: Streak-pattern stainless steel
 Armrest: ϕ 38 stainless steel single tube
 Floor: PVC floor



YMD-GG006 (optional)

Upper and lower shells: Steel panel with baked finish
 Window: Laminated glass
 Ceiling: Multilayer reflective processed panels and simple lights
 Car wall: Stainless steel panel with capillary crack
 Armrest: Stainless steel panel with capillary crack
 Floor: PVC floor



Observation Elevator



Classic car

YMD-GG007 (optional)

Upper and lower shells: Frame of steel panel with baked finish, and acrylic light fixture
Window: Laminated glass
Ceiling: Frame of steel panel with baked finish, acrylic top panel and downlight
Car wall: Streak-pattern stainless steel
Armrest: ϕ 38 stainless steel single tube
Floor: PVC floor



Control panel outbound system



Integral COP (optional)
10.4-inch LCD display



Standard COP
7-inch LCD display

Optional button



Elevator LCD video player

Product features:

- ★ Flexible display interface allowing modification and customization
- ★ Industry-grade super-low power consumption, embedded design, integrated structure, and high stability
- ★ Industry-grade color TFT LCD
- ★ Direct connection to serial signals of major elevator manufacturers without conversion board
- ★ Playing real-time network streaming media, VCD, DVD, and TV programs
- ★ Flexible installation, horizontal or vertical



Parallel call panel



TS-W01 Integrated call and fire fighting panel at the first-floor base station (embedded)



Acousto-optic floor indicator



TS-W06 luxury mirror polished titanium call panel (wall mounted)



Base station fire fighting panel (wall mounted)



Lock panel (wall mounted)



TS-W05 optional (wall mounted optional)



TS-W09 optional (wall mounted optional)



TS-W04 optional

Observation Elevator Attachment

Elegance and fashion

In addition to the amazing appearance, the elevators are also carefully crafted, of high quality and taste.

The Armrest



HSGF-02



HSGF-03



HSGF-05



HSGF-06

The Floor



TS-GB02



TS-GB05



TS-B05



TS-B04

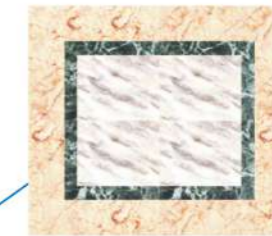

TS-B02



Color Swatches



JD158 Golden steel panel

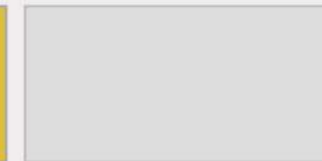

JD159 Silver steel panel



JD160 Beige steel panel

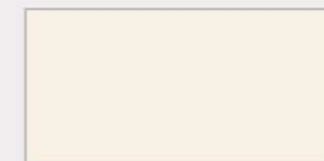

JD161 Barley white



JD162 Olive green

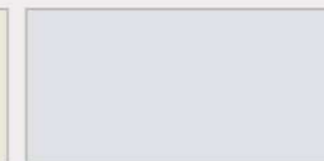

JD163 Pearl gray

Rebo features

Running

Full collective control

On the basis of the signal control, collect all the call signals and response selectively.

Direct running when fully loaded

When fully loaded, the car does not respond to external call signal and only implement the one inside.

Automatic returning to base station

Within the set time, if there is no internal or external call, the car will automatically return to the set floor (base station).

Automatic canceling opposite instruction

When the car is running, the opposite floor signal sent through the COP will be automatically canceled.

Automatic learning of distance between floors

The system can automatically record the height of the each floor so as to precisely control the distance of elevator running.

Automatic diagnosis of failure

The system can automatically diagnose and record the signal of failure of the elevator, and use special tools for quick troubleshooting.

Anti-trouble-making

The system will compare the car load against the instruction, and will automatically cancel the signals inside the car if there is only a few passengers but too many instructions.

Canceling the wrong instruction

If the elevator is not running, you can double click the call button of a certain floor to cancel the sent signal.

Door open and door close buttons

Inside the car there are door open and door close buttons. If the elevator is not running, you can press the door open button to open the door, and press the door close button to cancel the waiting time to close the door immediately, improving the efficiency of running.

Automatic correcting running

When the elevator is out of position, the elevator will automatically find the correct position.

Reopening the door in the hall of a floor

When the elevator stops at a floor, you can press the call button indicating the running direction of the elevator to reopen the door.

Torque compensation without weighing

When the elevator starts, no additional weighing switch is needed, the system will automatically carry out torque compensation based on the weight of the car, so as to guarantee comfort at the start.

Safety

End station protection

When the elevator arrives at the top floor but its speed has not been reduced to the speed set in the system, the protection device will force it to slow down to ensure safety.

Light curtain door protection

There is a light curtain protection web at the entrance of the elevator. Each scan cycle contains more than 94 infrared beams, with the reaction time being less than 0.1 second.

Door closing torque protection

If mechanical jam occurs when the car door closes, with the torque exceeding the predetermined value, the car door will reopen.

Overload alarm

When the weight of passengers inside the elevator exceeds rated capacity, the buzzer will send out an alarm signal to remind the passengers to leave the car and cancel the instructions sent from the car.

Delayed protection of car door opening and closing

When the elevator stops at a certain floor, if as a result of resistance or other factors, the door fails to open to the predetermined position within the set time, the elevator will enter the door opening protection mode, in which if the door still can't open successfully at three attempts, the elevator will then run to the next floor to open the door; if due to resistance or other factors, the door fails to close to the predetermined position within the set time, the elevator will enter the door closing protection mode, and not respond to the call instructions.

Motor overheating protection

If the temperature of motor exceeds the limit, the elevator will enter the standby mode after finishing the current running, and automatically resume operation when the temperature drops to normal range.

Abnormal speed detection

Through comparing the feedback signals of the encoder and the speedset in the system, the system can control the running speed of the elevator. Once the difference between the two exceeds the allowed range, the system will enter the protection mode, stopping the elevator from running.

Detection of Contactor abnormality

The system monitors the main contactor and the brake contactor based on the command status of the contactors. In case of detecting any abnormality, the system will enter the protection mode, stopping the elevator from running.

Detection of power supply system abnormality

If the fluctuations in the power supply system exceed a certain range, resulting in phase dislocation and phase loss, the system will enter the protection mode, stopping the elevator from running.

Detection of brake abnormality

When the system sends out a command of running but detects that the brake is not opened, or the system does not send out a command of running, but detects that the brake is opened, the elevator will be protected and stopped from running.

Emergency devices

Machine-room emergency electrical running

There is machine-room emergency electrical running devices inside the control cabinet. In case of emergencies, professionals can operate the elevator in the machine room.

Emergency lighting in the car

Inside the car there should be equipped with emergency lighting.

Alarm in the car

In case of emergencies, passengers can press the alarm button on the COP to seek help.

Energy conversation

Automatic control of lightning and fan in the car

If there is no call signal within the set time, the lighting devices and fan inside the car will be automatically shut down to save energy.

Canceling door close waiting time

By pressing the close button inside the car, the car door will be immediately closed.

Elevator lock switch

After the elevator lock switch is turned on, the system will no longer respond to any calls and automatically return to the base station after responding to all the instructions sent from the car.

Control of door open waiting time

The system can set different door open waiting time responding to calls from outside and inside the car if required.

Human-Machine interface

LCDs in the car and the hall

Color COP and LCDs for calls display information on floors and the running direction of the elevator.

Car arrival chime

When the elevator arrives at a station, the car arrival chime will ring to remind passengers that the elevator has arrived.

Directional indicator in the hall and the car

When the elevator is running, the running direction will be displayed on the call panel and display in the car.

Customized floor display settings

The floor display information can be customized based on the customers' needs, which may include any two characters, one from 0 to 9, the other A to Z (please be noted that 0 cannot be distinguished from 0, 2 from Z, 5 from S, and 8 from B).

Special running

Automatic parking

Based on the results of integrating the information on all floors, the elevators will be automatically parked on different floors, improving the working efficiency.

Five-party interphone

The car, car bottom, car ceiling, machine room and monitor room form an interphone system.

Switch for canceling the call from the hall

There is a switch on the mainboard. So the call instructions will be canceled simply by dialing, making it convenient for debugging and maintenance.

Static positioning

When installing the elevator, there is no need to disengage the steel wire rope from the motor to position the motor at a certain angle, hence easy installation.

Car ceiling inspection and repair

There is an inspection and repair switch on the car ceiling for the convenience of the maintenance personnel to carry out maintenance work in the hoistway. If the switch is on, the inspection and repair switch in the machine room is disabled.

Optional features

Running

Re-leveling

When the elevator door opens, the steel wire rope stretching caused by the entry of passengers causes the elevator leveling position to change. Under this circumstance, the elevator will automatically level to the correct position at a very slow speed.

Down collective operation

When the down collective operation is selected, the up button is only available on the base station or the ground floor, and on the other floors there is only down button.

Operator services

If the car is equipped with the driver switch and when it is on, the elevator will start operator services and controlled by the operator in opening and closing the door.

Independent services

If the car is equipped with the independent service switch and when it is on, the elevator will get out of group control and not respond to the call instructions.

Direct travel by operator

When the operator switch is on, the operator will press the direct travel switch to bypass all the calls. The elevator will not respond the calls until the direct travel switch is off.

Door open hold switch

The car is equipped with a door open hold switch and when it is on, the door will not be closed within the set hold time, after which the door will be automatically closed. During the hold time, the passenger can press the door close button to cancel the door open hold and immediately close the door.

Parallel/group control function

The parallel function is available when there are two elevators, and group control function for three. When the parallel/group control function is activated, the system will, based on the priority of calls, send the fastest possible elevator to respond to the call instructions, so as to reduce the waiting time.

Timer switch

Timing equipment is added for all-weather control of the elevator.

Human-Machine interface

Elevator air conditioner

An air conditioner can be equipped to keep the temperature in the car within a range in which passengers feel comfortable.

Arrival chime in the hall

Usually an arrival chime will be integrated into the call display in the hall.

Voice indicator

A voice indicator is equipped to accurately tell passengers which floor the elevator arrives, door status and etc.

Energy-efficient display in the hall

If there is no call signal after a long time, the display in the hall will automatically enter energy-saving mode.

Safety

Intelligent IC card management

When the IC card function is activated, only the card holder can use the elevator by swiping the card.

Password-protected services

When this function is activated, calls of certain floors can be prohibited by setting a password, and only those who enter the correct password have the right to call the floor.

Emergency fire-fighting switch

The base station is often equipped with an emergency fire-fighting switch and when it is on, the elevator will cancel all the sent instructions and directly travel to the fire-fighting floor before opening the door and responding to ant calls.

Community monitoring system

Special video devices can be equipped to monitor the real-time status of the car.

Emergency rescue device for power outage

When the elevator is equipped with the device, it will automatically switch to the emergency rescue mode in case of power outage, stopping on the nearest floor and then opening the door while pacifying passengers with voice message.

Light curtain door protection

In the process of door closing, if the infrared beams covering substantially the entire height of the door detect passengers and objects, the door will be re-opened.

Schematic Diagram of Civil Engineering of Observation Elevator with Square Organic Glass Window

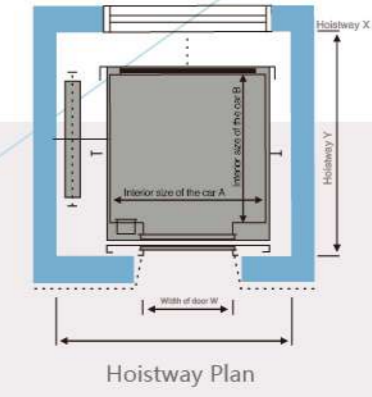
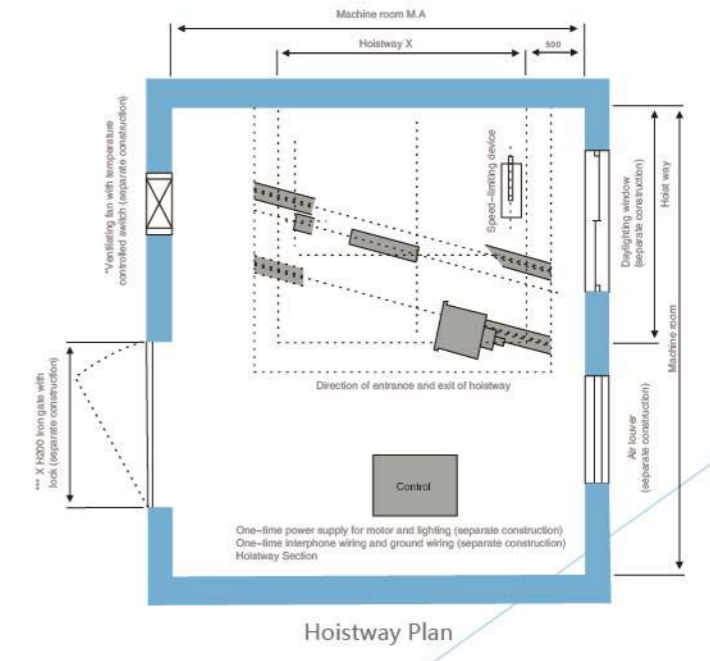
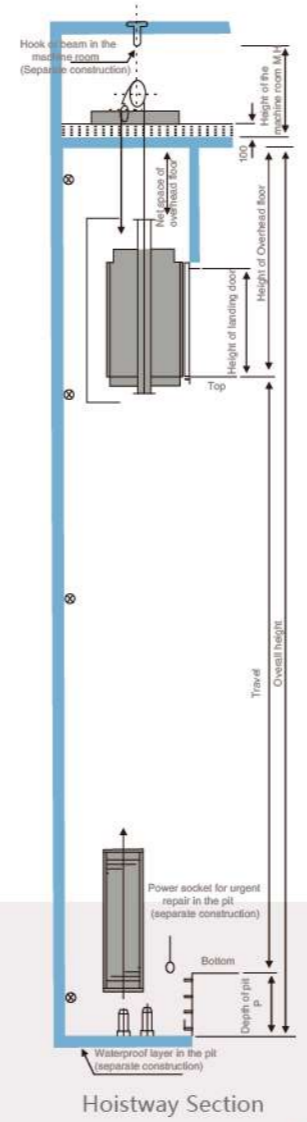
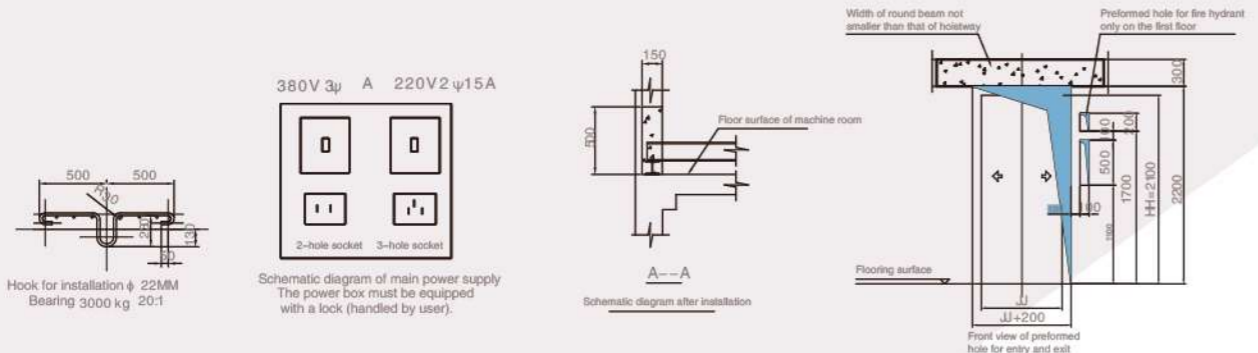

Parameter Table

Load (kg)	Passenger number	Speed (m/min)	Dimension of internal car A x B x C	Doorway width (mm)	Hoistway dimension (mm)				Machine room dimension (mm)		Motor capacity (kw)	Max. number of floor stops (S)	Max. stroke (m)
					XxY	T	OH	P	MaxMB	MH			
630	8	60	1400 x 1100 x 2500	800	2200 x 1700	1300	4300	1500	3100 x 3600	2250	7.5	24	60
		90				1500	4500	1700			9.5	40	125
		10.5				1500	4500	1700			9.5	40	125
800	10	60	1400 x 1350 x 2500	800	2200 x 1850	1300	4300	1500	3150 x 3750	2250	7.5	24	60
		90				1500	4500	1700			11	40	125
		10.5				1500	4500	1700			13	40	125
1050	13	60	1600 x 1500 x 2500	900	2450 x 2100	1300	4300	1500	3500 x 4100	2500	9.5	24	60
		90				1500	4500	1700			13	40	125
		10.5				1500	4500	1700			15	40	125

Schematic Diagram of Civil Engineering of Observation Elevator with Diamond Organic Glass Window

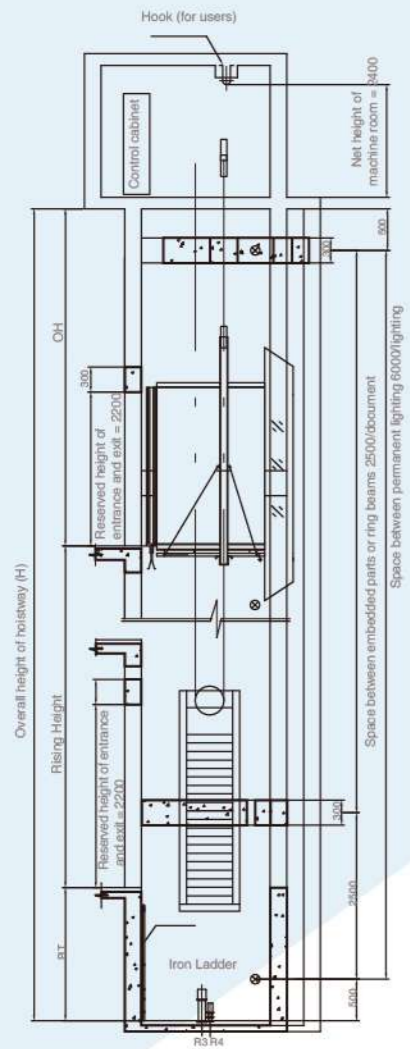

LIFTING ROAD PROFILE

1. Do not use the space under the pit.
2. The height of each floor must be double-checked and in compliance with the actual dimension confirmed on the construction site for the sake of installation of elevator parts.
3. If there is water that can't be drained in the pit, a water pit and pumping motor are required to keep the elevator parts in good conditions.
4. Motors should have OL protector.

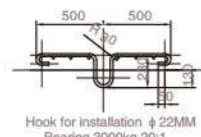

380V 3 ψ A 220V 2 ψ 15A

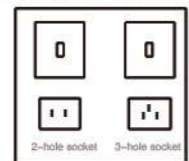

Schematic diagram of main power
The power box must be equipped with a lock (handled by user).

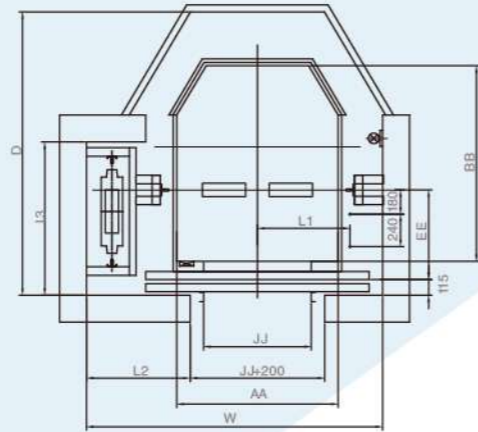

HOISTWAY PLAN

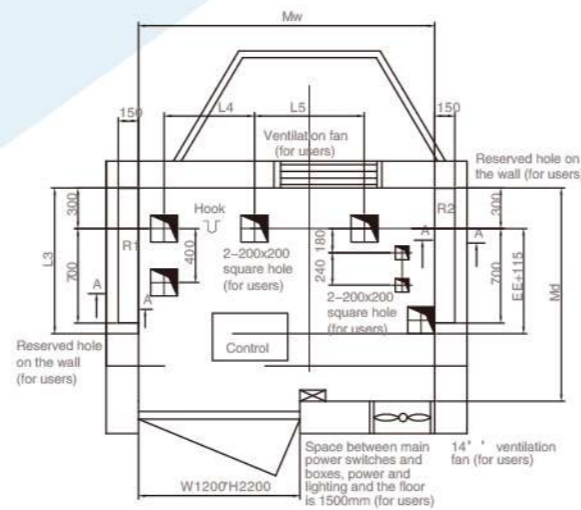

PLAN OF MACHINE ROOM

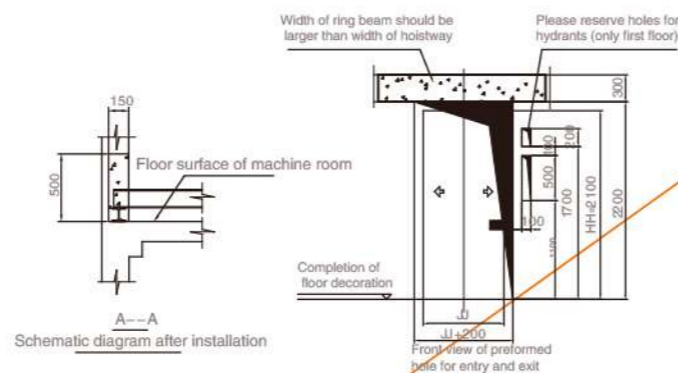

Parameter Table

Capacity (kg)	Speed (m/min)	Passenger number	Dimension of internal car A/B/C	Door opening size (mm)J	Hoistway dimension (mm)					Other positioning size (mm)					Machine room dimension (mm)	Counterforce of hoist way side walls (N)		PI counterforce (N)	Power of motor (KW)	Air switch of power supply (A)	Diameter of power cable (mm)	
					W x D	O	H	P	T	EE	L1	L2	L3	L4		L5	Mw x Md					R1
630	1.0	8	1300x1350x2500	800x2100	2250x2100	4800	1800								2250x3000	50000	40000	75000	57000	4.5	40	10
	1.5				5200	2000	650	738	800					96000				70000	8.8	65		
	1.75									720	900											
800	1.0	10	1300x1650x2500	800x2100	2250x2200	4800	1800							2250x3000	50000	40000	75000	57000	5.5	40	10	
	1.5				5200	2000	760	738	800	1300												
	1.75																					
1050	1.0	13	1600x1500x2500	900x2100	2450x2200	4800	1800							3450x3100	55000	42000	85000	65000	6.7	40	10	
	1.5				5200	2000	810	838	900	770	1000											
	1.75																					

Schematic Diagram of Civil Engineering of Observation Elevator with Semicircle Organic Glass Window

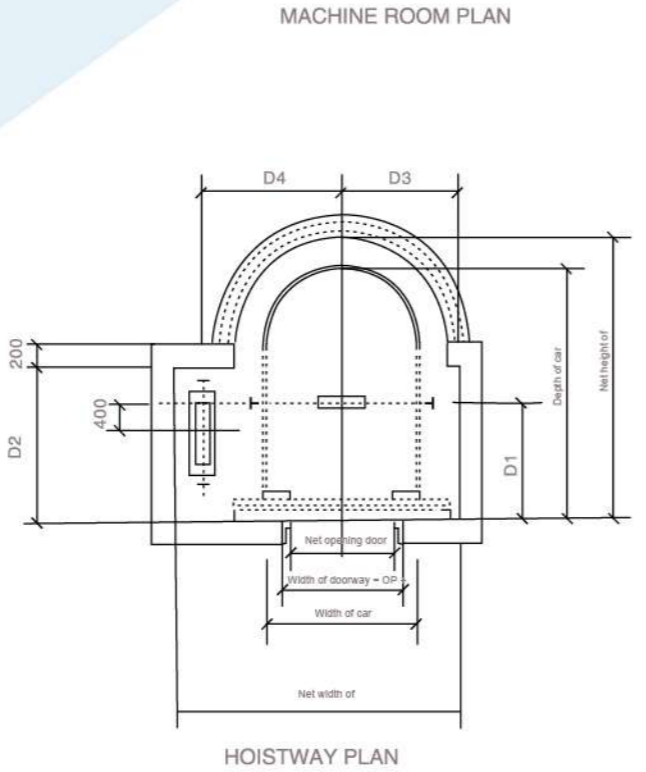
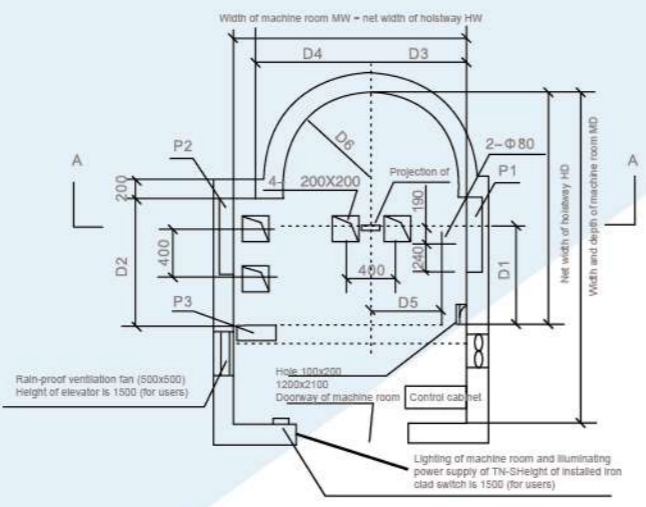
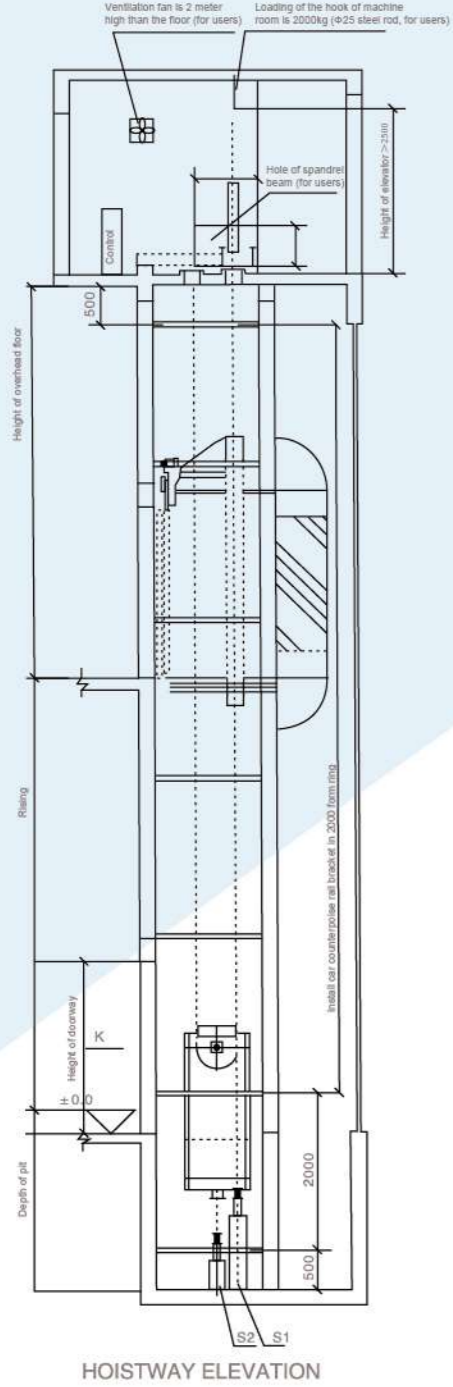

Notes for owners and civil engineering contractors

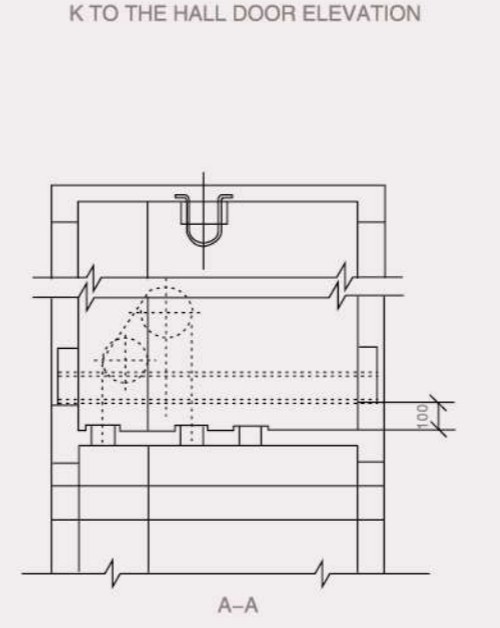
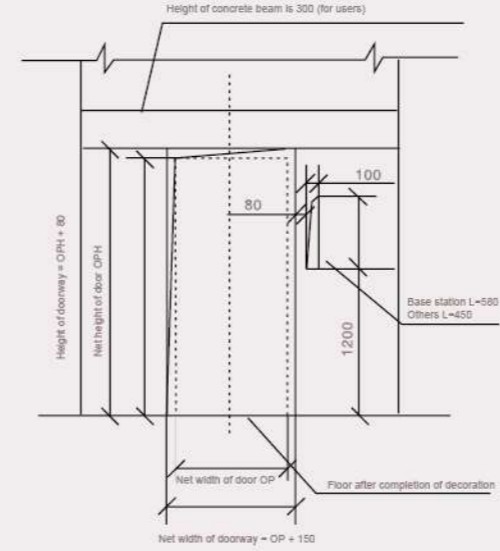

- All structures in the hoistway must meet the requirements for fire fighting; any equipment, power supply or holes for any other purposes are not allowed in the hoistway.
- The walls should be vertical; the horizontal dimension of hoistway is the minimal net distance between walls; and the vertical deviations are as follows: 0-+25mm/0-30mm, 0-+30mm/30mm-60mm, and 0-+50mm/60mm and above.
- The hoistway should not be built above the space where people have access to. If there is such space, the buffer of counterweight should be installed on a solid pier extended to the firm ground, or the user should consult the elevator manufacture about the installation of counterweight safety gear.
- Before the installation of elevator, all floor door openings must have at least 1.2m-tall protective fences of sufficient strength.
- A ventilation hole covered with protective net should be opened in the closed hoistway as needed (usually on the top or bottom of the hoistway), with its area being not less than 1% of the horizontal section of the hoistway.
- The preformed holes for elevator floor doors, call display and etc. should be filled and furnished after the installation of the elevator.
- Preferably, the hoistway is made of concrete. If the hoistway is of brick and concrete structure, a 300mm-high concrete ring beam should be installed at the location where the guide rail bracket is installed; if solid load-bearing brick structure, a 300mm-high concrete beam of the width of the hoistway on both the higher and lower ends of the preformed holes for each floor door.
- When the distance between two adjacent sills is more than 11m, there should be a safety door of the dimension not smaller than 350mm x 1800mm (W x H) between them.
- The pit should be waterproof; if there is a water pit, it should be located in the corner.
- According to requirements of the technical parameters table, the power supply should be connected to the machine room, controlled by protective switch and locked. Power fluctuation should be within the range of $\pm 7\%$; the neutral and ground wires are separated, and the ground resistance is smaller than 4.
- All loads indicated, unless otherwise stated, include the allowance for impact, and the hoistway walls and pit must be of the strength large enough to bear the indicated loads.
- The parts marked "handled by user" (embedded steel for example) should be handled in advanced.
- The room temperature of the machine room should range from 5 to 40 °C; the floor should be flat and be able to bear not less than the standard uniformly distributed live load per square meter of 7.0KN.
- The users need to set up a rescue duty room and communication wiring towards the machine room; if the length of cable between the duty room and machine room is less than 500m, a 6-shielded twisted-pair cable (3 x 2 x 0.75mm²) is require; if larger than 500m, greater than 500 meters, one category 5 cable.

Parameter Table

Capacity (kg)	Speed (m/s)	Passenger number	Car dimension (mm) AA×BB×CC	Door opening size (mm) DP×DHP	Hoistway dimension (mm) HW×HD	Machine room dimension (mm) MW×MD×MH	Depth of pit (mm) PH	Height of overhead floor (mm) OH	Other dimensions (mm)					Pit bearing capacity (kN)			Machine room bearing capacity (kN)			Max. corner of floor slope	Max. rising height (m)
									D1	D2	D3	D4	D5	S1	S2	P1	P2	P3			
630	1.0	8	1100×1600×2500	800×2100	2250×2210	2250×3210×2500	1750	4550	830	1340	950	1100	645	84	65	52	46	10	16	52	
	1900						4750	24											80		
	2000						4800	36											122		
800	1.0	10	1200×1740×2500	800×2100	2350×2320	2350×3320×2500	1750	4550	955	1450	960	1100	695	90	68	57	52	13	16	52	
	1900						4750	24											80		
	2000						4800	36											122		
1050	1.0	13	1600×1500×2500	900×2100	2400×2600	2400×3560×2500	1750	4550	1020	1500	1010	1160	745	92	71	62	54	14	16	52	
	1900						4750	24											80		
	2000						4800	36											122		

Schematic Diagram of Civil Engineering of Observation Elevator with Diamond Inorganic Glass Window

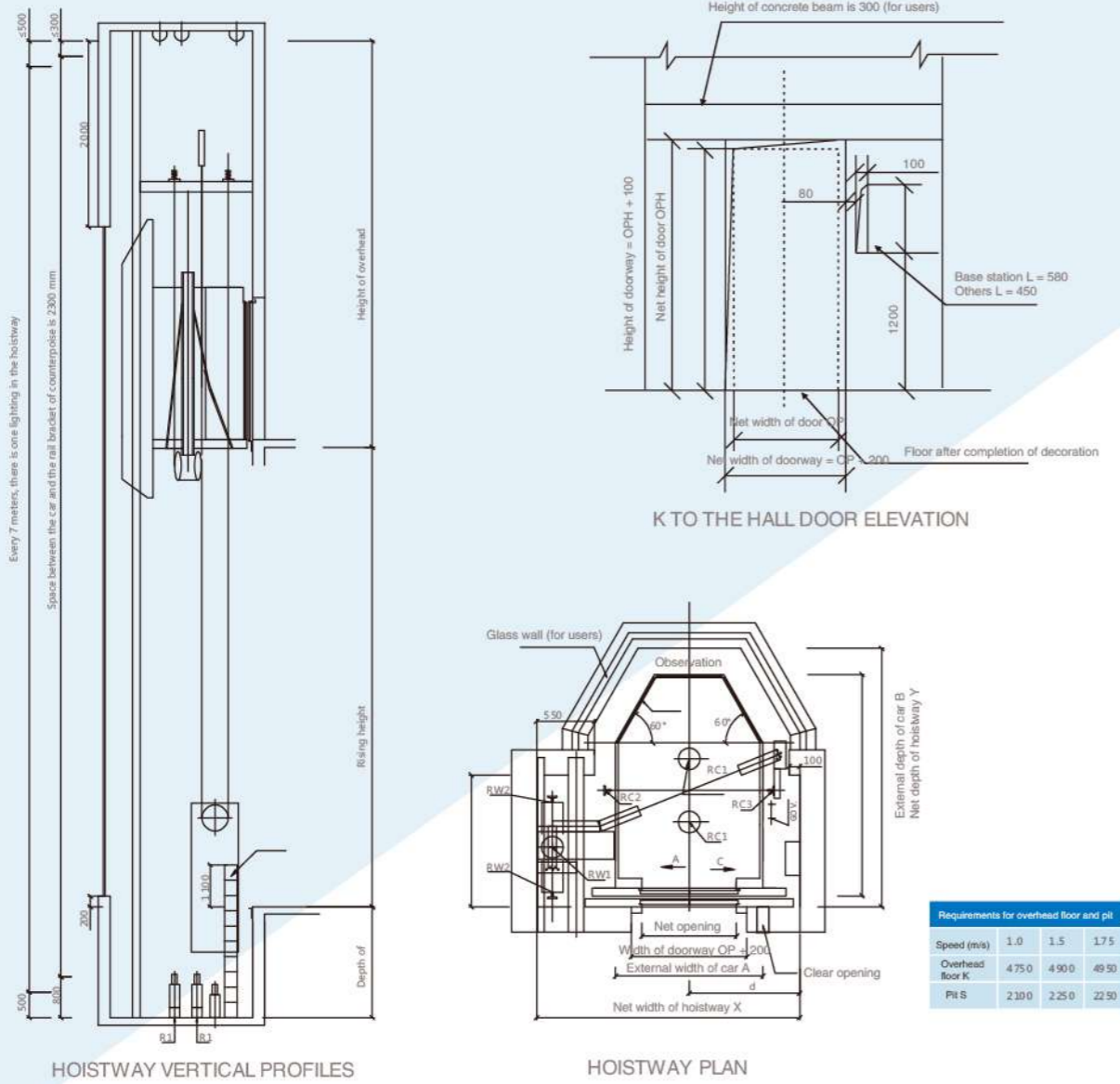

Parameter Table

Capacity-speed (kg-m/min)	Car dimension (mm x mm)	Door opening size (mm)		d (mm)	CE (mm)	Hoistway dimension (mm)		Bearing capacity (N)						
		(A x B) External dimension	Type			Doorway width OP	Doorway height OPH	X	Y	RC1	RC2	RC3	RW1	RW2
8 00-1.0 ~ 1.75	1200x2050	2P-CO	800	2100	950	1250	2300	2400	100 500	70 500	26 000	9 5000	14000	64 000
10 00-1.0 ~ 1.75	1400x2100	2P-CO	900	2100	1050	1250	2500	2500	120 000	72 000	30 000	100000	15000	65 000

Notes: 1) 2P-CO double-fold center opening door.
The elevator is suitable for buildings of at least 2800mm high; if the building is shorter than 2800mm, the designs of some structures such as corbels have to be revised. Please contact Xizi Xiao for more technical details about the hoistway, preformed holes for hall (floor) doors and etc.

Schematic Diagram of Civil Engineering of Observation Elevator with Square Organic Glass Window

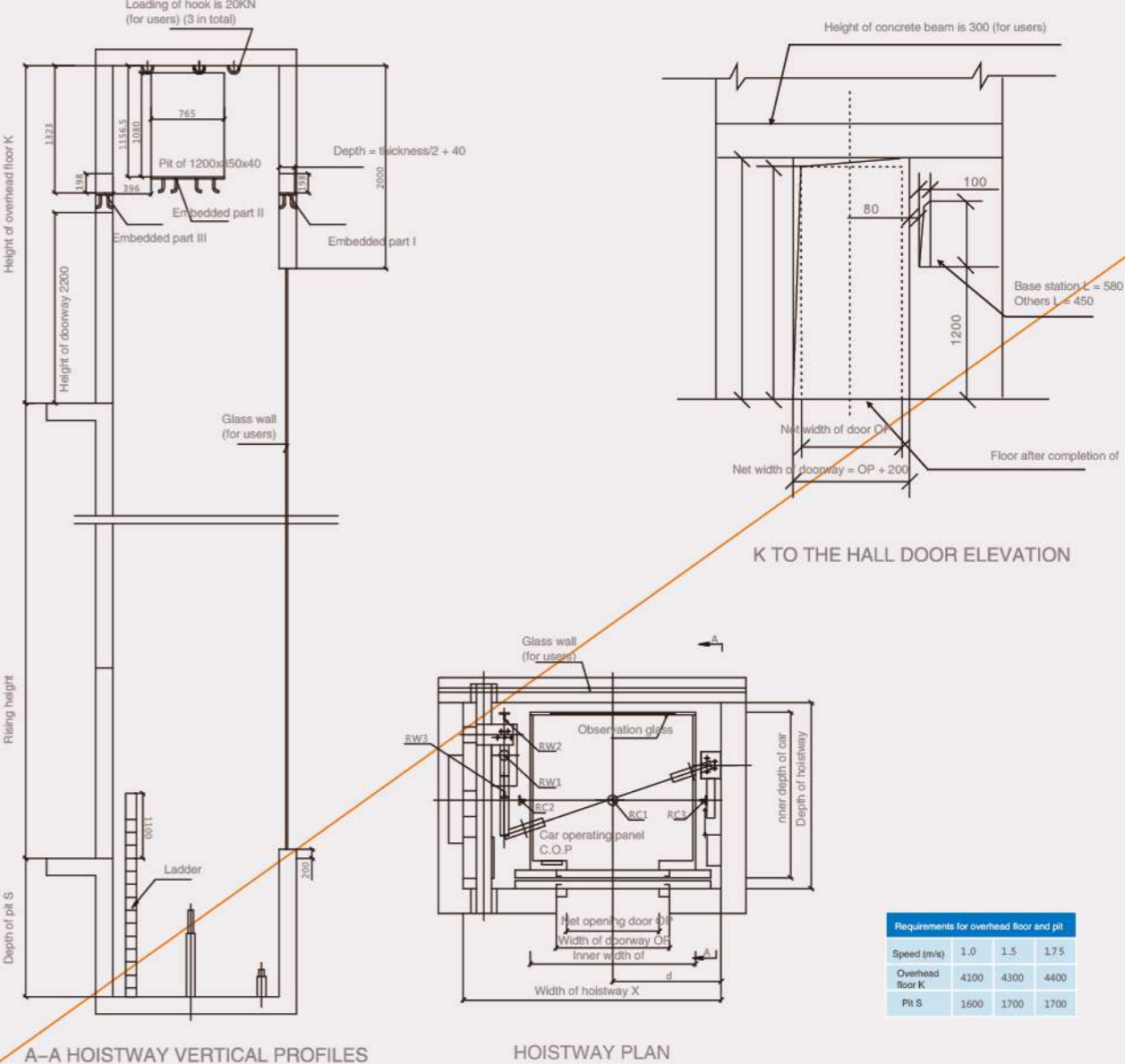

Parameter Table

Capacity-speed (kg-m/min)	Car dimension (mm x mm)	Door opening size (mm)		d (mm)	Hoistway dimension (mm)		Bearing capacity (N)						
		(A x B) External dimension	Type		Doorway width OP	Doorway height OPH	X	Y	RC1	RC2	RC3	RW1	RW2
8 00-1.0 ~ 1.75	1400x1350	2P-CO	800	2100	950	2300	1800	100500	70500	26000	95000	14000	64000
10 00-1.0 ~ 1.75	1600x1480	2P-CO	900	2100	1050	2500	2000	120000	72000	30000	100000	15000	65000

Notes: 1) 2P-CO double-fold center opening door.
The elevator is suitable for buildings of at least 2800mm high; if the building is shorter than 2800mm, the designs of some structures such as corbels have to be revised. Please contact Xizi Xiao for more technical details about the hoistway, preformed holes for hall (floor) doors and etc.

Schematic Diagram of Civil Engineering of Observation Elevator with Semicircle Inorganic Glass Window

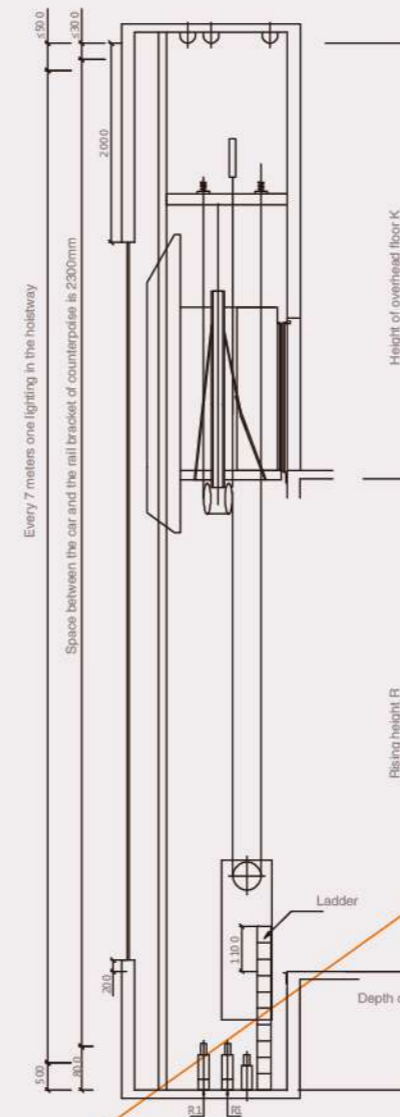

HOISTWAY VERTICAL PROFILES

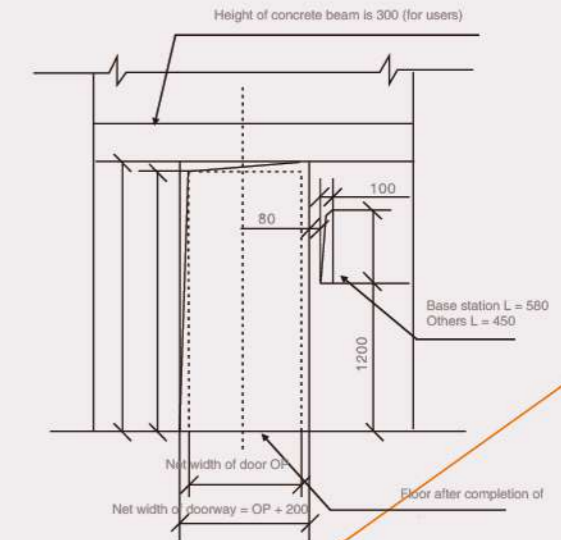

K TO THE HALL DOOR ELEVATION

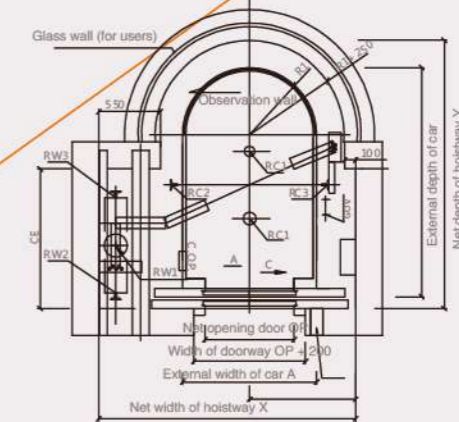

HOISTWAY PLAN

Requirements for overhead floor and pit						
Speed (m/s)	1.0	1.5	1.75			
Overhead floor K	4750	4900	4950			
Pit S	2100	2250	2250			

Parameter Table

Capacity-speed (kg-m/min)	Car dimension (mm x mm)	Door opening size (mm)			R1 (mm)	CE (mm)	Hoistway dimension (mm)		Bearing capacity (N)					
		(A x B) External dimension	Type	Doorway width OP			Doorway height OPH	X	Y	RC1	RC2	RC3	RW1	RW2
800-1.0-1.75	1200x2050	2P-CO	800	2100	600	1250	2300	2400	100500	70500	26000	95000	14000	64000
1000-1.0-1.75	1400x2100	2P-CO	900	2100	700	1250	2500	2500	120000	72000	30000	100000	15000	65000

Notes: 1) 2P-CO double-fold center opening door.
The elevator is suitable for buildings of at least 2800mm high; if the building is shorter than 2800mm, the designs of some structures such as corbels have to be revised. Please contact Xizi Xiao for more technical details about the hoistway, preformed holes for hall (floor) doors and etc.